

## ACL reconstruction with bone-tendon-bone transplants using the ENDOBUTTON CL BTB Fixation System

Stuart Fromm, M.D.



## ACL Reconstruction with Bone-Tendon-Bone Transplants

As described by Stuart Fromm, M.D.

In the late 1980s Smith & Nephew's ACUFEX® instrumentation helped standardize ACL reconstruction.

In 1999 the Smith & Nephew ENDOBUTTON CL Fixation Device for hamstring tendons further simplified ACL reconstruction and increased initial reconstruction strength.

With the increasing popularity of bone-tendon-bone grafts, Smith & Nephew developed the ENDOBUTTON CL BTB Fixation System. This new BTB system offers the surgeon many advantages: the bone blocks are fully appositioned in the femoral tunnel, thus the tibial and femoral bone blocks cannot protrude; perforation of the posterior femoral cortex will not compromise fixation; and revisions become simpler. In addition, by directly obtaining the measurements for the total graft length, femoral tunnel length, and desired graft insertion depth, calculation is eliminated and potential errors are minimized. The technique is easy, reproducible, dependable, and delivers a strong fixation that avoids complications seen with interference screws such as screw divergence, posterior blow-out, laceration of the graft, and screw breakage.

Stuart Fromm, M.D.  
Black Hills Orthopedic & Spine Center, P.C.  
Rapid City, South Dakota

## Graft Harvesting and Preparation

If necessary perform appropriate notchplasty using the Smith & Nephew NOTCHMASTER<sup>®</sup> Curette or Smith & Nephew NOTCHBLASTER<sup>®</sup> Burr).

Harvest the bone-patella-bone tendon graft in the preferred manner (Figure 1). Recommended bone plug lengths are 20 mm.

1. Measure the overall length of the graft (Figure 2; example: 90 mm).
2. Prepare the desired bone plug diameters in the preferred manner, e.g., utilizing Smith & Nephew COMPACTION<sup>®</sup> Pliers. Measure bone block diameters using sizing tubes.
3. Drill a 2.0 mm diameter hole in the femoral bone block perpendicular to the cortex (Figure 2). This hole should be placed at the midpoint of the bone block or toward the bone tendon junction. The continuous loop of the ENDOBUTTON CL BTB Fixation System will eventually be passed through this hole. If you desire to pass the Continuous Loop (CL) at the bone-tendon junction, a 2 mm hole in the femoral bone block is needed for a #2 guide suture. The #2 guide suture is used to keep the femoral bone block concentric with the bone tunnels when pulling the graft through.

4. Depending on the type of tibial fixation used, prepare the tibial bone block in the preferred manner.

For an exceptionally long graft, you may need to adjust the tunnels as described under the Tibial Tunnel Positioning and Femoral Tunnel Location sections.



Figure 1: Graft harvesting site

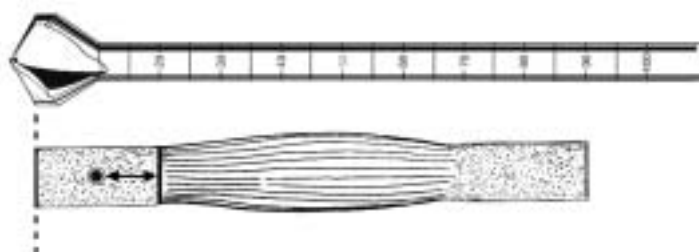

Figure 2: All-over graft length and hole



Figure 3: Positioning of the tibial aiming device

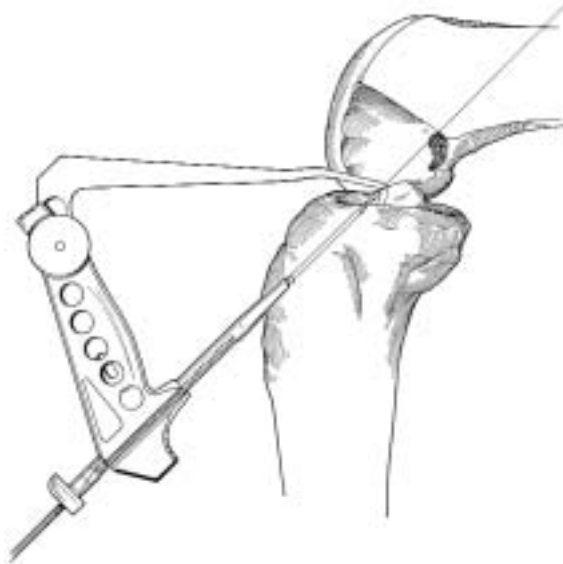

Figure 4: Placing of the 2.4 mm guide wire

### Tibial Tunnel Positioning

Position the tibial tunnel using the Smith & Nephew ACUFEX® DIRECTOR® Drill Guide as follows (Figure 3):

The remaining distal stump of the torn ACL is the major orientation guide.

#### Using the Elbow Aimer:

place the tip of the aimer in the posterior fibers of the ACL footprint. The 2.4 mm guide wire will protrude through the tibial plateau several millimeters anterior (depending on the angle of the tibial tunnel) to the tip of the aimer.

**Using the Tip Aimer:** place the tip of the aimer exactly at the point where the 2.4 mm guide wire will protrude through the tibial plateau.

Place the 2.4 mm guide wire in the preferred position (Figure 4). The angle of the aimer may be adjusted depending on the graft length. To achieve a longer tibial tunnel, increase the angle of the aimer arm.

## Tibial Tunnel Drilling

Confirm the exact diameter of the bone blocks and perform notch assessment prior to drilling.

If necessary, reposition the 2.4 mm guide wire using the Offset Guide.

Drill the tibial tunnel using a standard Cannulated Drill Bit that matches the graft diameter (Figure 5).

## Femoral Tunnel Location

The knee is usually flexed at 90°. Position the endoscopic femoral aimer with the appropriate offset hook (Figure 6: X mm) at the over-the-top position, in direct contact with the bony cortex.

**Note:** When using the ENDOBUTTON CL BTB System for femoral fixation, perforation of the posterior femoral cortex does not compromise fixation.

If a longer femoral tunnel is desired (e.g., with an exceptionally long graft), the knee can be flexed slightly less than 90° (Figure 7).

Advance the 2.7 mm passing pin through the femoral offset guide and drill through the femur until the passing pin “breaks” through the lateral femoral cortex.

Feel the 2.7 mm passing pin just under the skin after it exits the cortex to determine its position with respect to the tourniquet.



Figure 5: Drilling the tibial tunnel

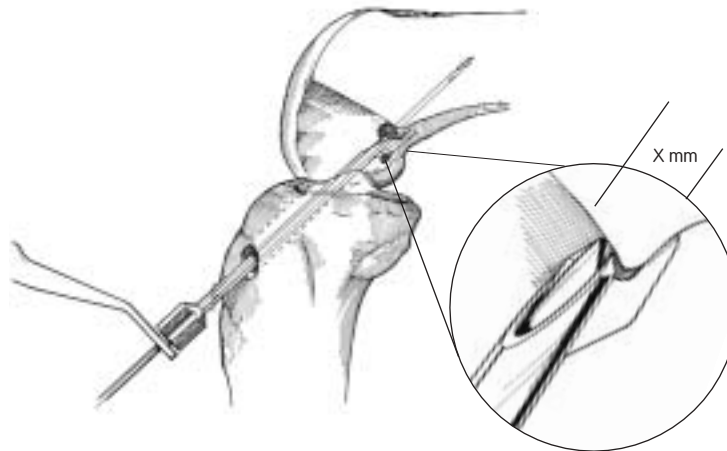

Figure 6: Positioning the endoscopic femoral aimer at the over-the-top position

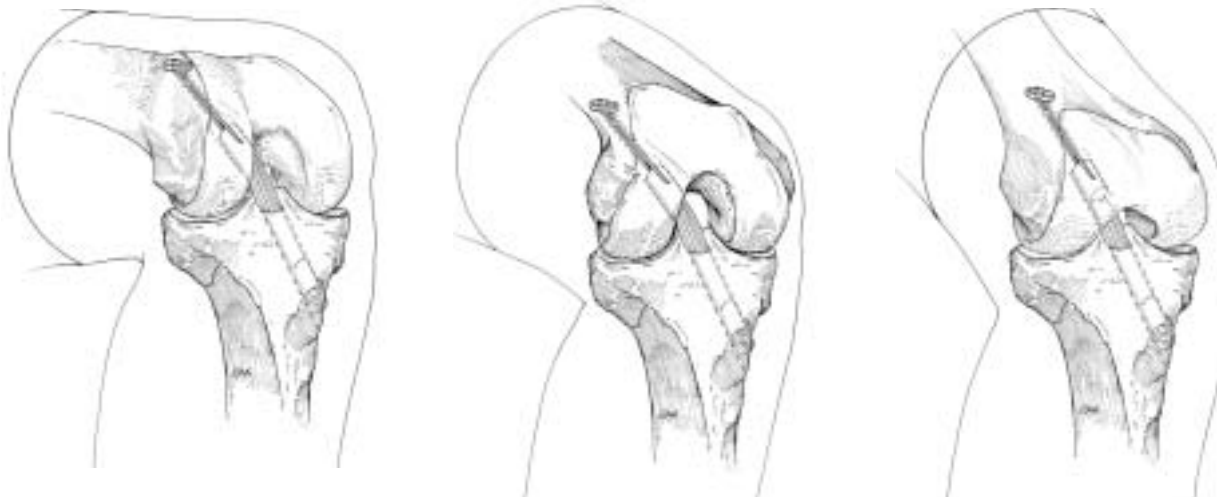

Figure 7: Femoral tunnel lengths with knee in different flexions

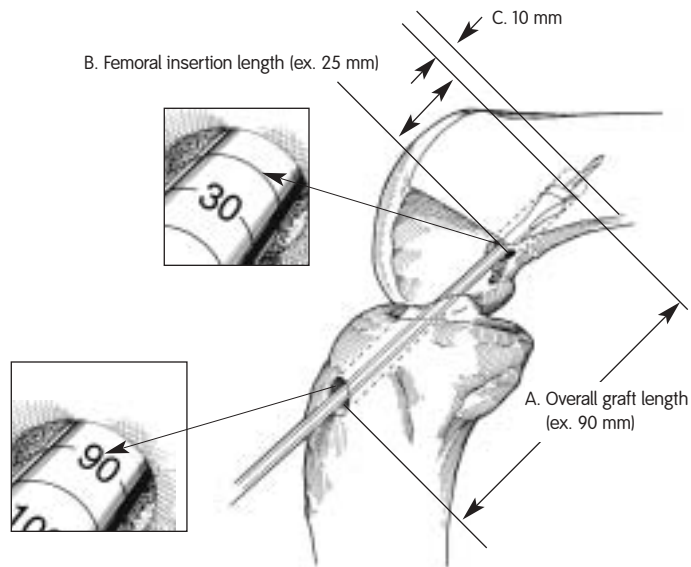

Figure 8: Femoral socket drilling

## Femoral Tunnel Drilling

The endoscopic cannulated drill bit will mimic the ACL graft, allowing for a direct determination of femoral tunnel depth. To position the tibial bone block of the bone-tendon-bone graft flush with the distal tibial tunnel:

1. Advance the endoscopic cannulated drill bit over the 2.7 mm passing pin. Measuring directly off the drill bit where it enters the tibial tunnel, drill the femoral socket to a depth matching the overall length of the bone-tendon-bone graft (Figure 8-A). Example: if the total graft length is 90 mm, drill the femoral tunnel to a depth where 90 mm is read directly off the endoscopic cannulated drill bit where it enters the tibial tunnel.

**Caution:** Ensure the endoscopic cannulated drill bit does not breach the lateral femoral cortex, otherwise femoral fixation with the ENDOBUTTON CL BTB System will be compromised.

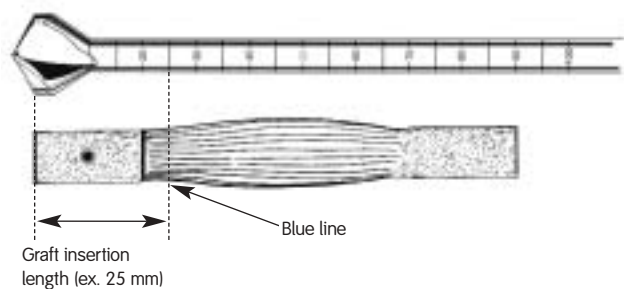

Figure 9: Marking the graft

2. With the endoscopic cannulated drill bit pushed against the back wall of the femoral socket, directly read the measurement off the drill bit at the base of the femoral socket (Figure 8-B; example: 25 mm). Using a surgical marker, place a corresponding “blue line” on the graft (Figure 9). This mark indicates the depth of the graft in the femoral tunnel.

3. With the endoscopic cannulated drill bit still in place, drill the femoral socket an additional 10 mm minimum (Figure 8-C) to allow the ENDOBUTTON device to be rotated once passed.



Figure 10: Drilling with the ENDOBUTTON Drill through the cortex

**Caution:** Ensure the endoscopic cannulated drill bit does not breach the lateral femoral cortex, otherwise femoral fixation with the ENDOBUTTON CL BTB System will be compromised.

4. With the 2.7 mm passing pin still in place, use the 4.5 mm ENDOBUTTON Drill Bit to drill completely through the femoral cortex (Figure 10).

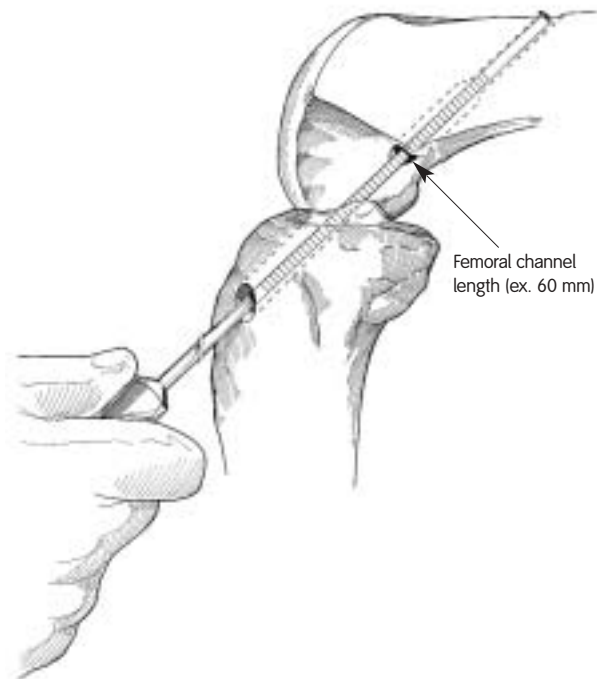

Figure 11: Measuring the femoral channel

### Determination of the CL Length

Measure the total length of the femoral channel length using the ENDOBUTTON Depth Probe (Figure 11; example: 60 mm). This will correspond to the distance from the ENDOBUTTON device to the “blue line” on the graft.

Position the graft on the ENDOBUTTON Holder of the GRAFTMASTER® Graft Preparation Board such that the “blue line” aligns at the distance obtained from the ENDOBUTTON Depth Probe (Figure 12; example: 60 mm from the ENDOBUTTON device).

The Continuous Loop (CL) length needed is read directly off the ENDOBUTTON Holder at the desired point of attachment to the graft.

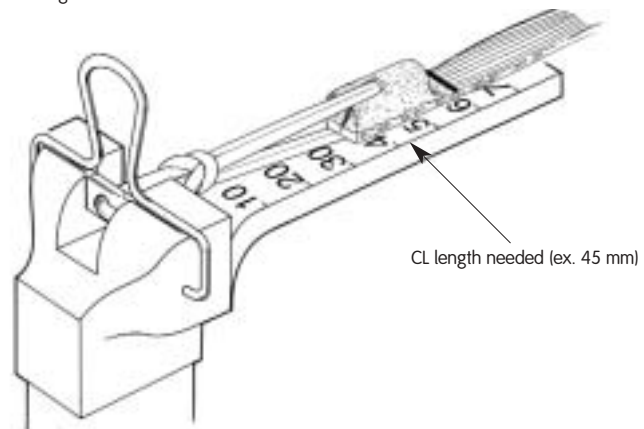

Figure 12. Determination of CL length on the GRAFTMASTER® Board

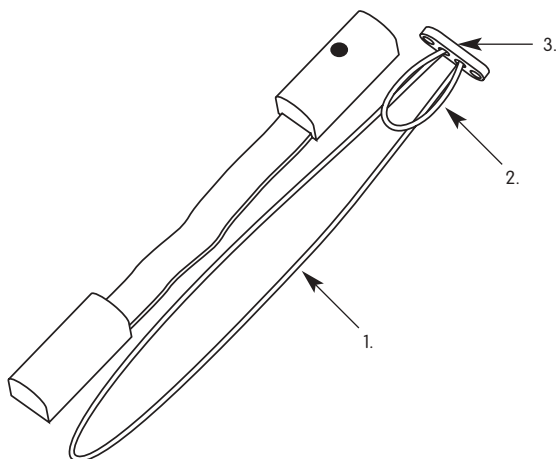

Figure 13: ENDOBUTTON CL BTB components

### Attaching the ENDOBUTTON CL BTB Fixation System to the Graft

The ENDOBUTTON CL BTB System can be divided into three distinct “areas” (Figure 13):

1. Long CL loop
2. Short CL loop
3. ENDOBUTTON Fixation Device

Pass the Continuous Loop (CL) through the graft and attach it to the ENDOBUTTON device as shown in Figure 14.

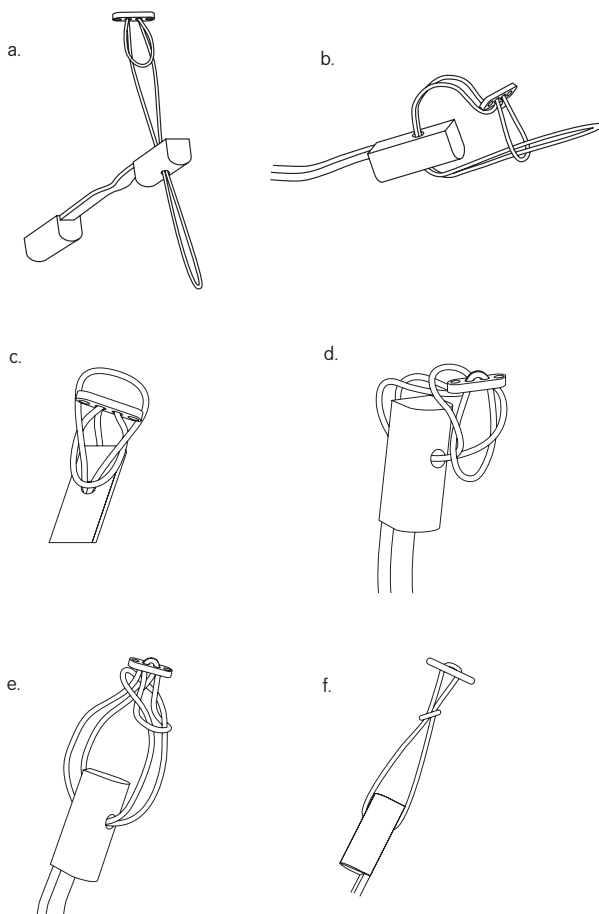

Figure 14: Attaching the ENDOBUTTON CL BTB System

1. Feed the long CL loop through the prepared hole of the femoral bone block (respectively through the desired position at the tendon-bone junction). The short CL loop should face toward the bone block (Figure 14-a).

2. Feed the long CL loop through the short CL loop (Figure 14-b).

3. Slip the long CL loop over the ENDOBUTTON device (Figures 14-c and d).

4. Tighten the construct (Figures 14-e and f).

## Graft Passage

Attach a #5 polyester braided suture to one outside hole of the ENDOBUTTON device to lead and pass the ENDOBUTTON device. Attach a trailing #2 polyester braided suture to the opposite outside hole of the ENDOBUTTON device to rotate the ENDOBUTTON device as it exits the anterolateral femoral cortex. Both sutures are passed through the eyelet of a passing pin (Figure 15).

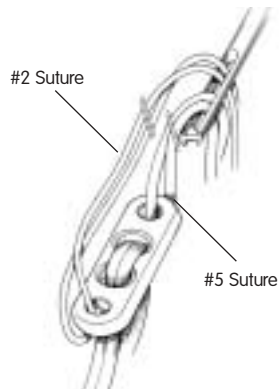

Figure 15: Attachment of leading and trailing suture to the ENDOBUTTON device

The passing pin is used for suture passage by piercing the quadriceps and skin proximally. The #5 suture is pulled first, advancing the ENDOBUTTON/graft complex into the femoral tunnel (Figure 16) until the ENDOBUTTON device has cleared the femoral cortex.

The trailing #2 suture is pulled, rotating the ENDOBUTTON device immediately external to the femur (Figure 17).

Hold the ENDOBUTTON device perpendicular to the femoral cortex and pull back on the graft, locking the ENDOBUTTON device on the outer femoral cortex. Secure fixation should be felt at that point with the “blue line” flush at the base of the femoral tunnel.

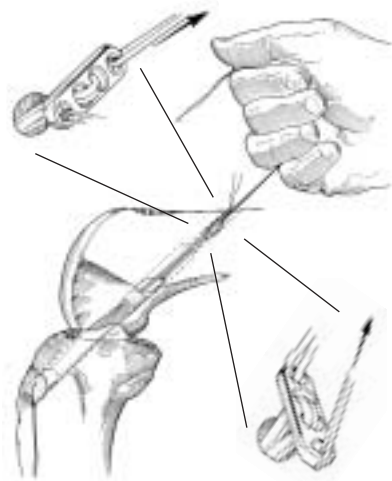

Figure 17: Rotating the ENDOBUTTON device outside the cortex

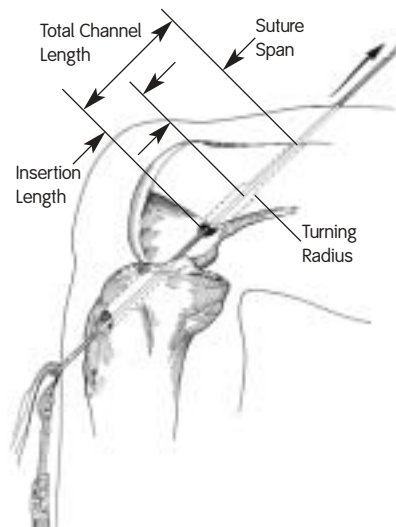

Figure 16: Passage of the graft

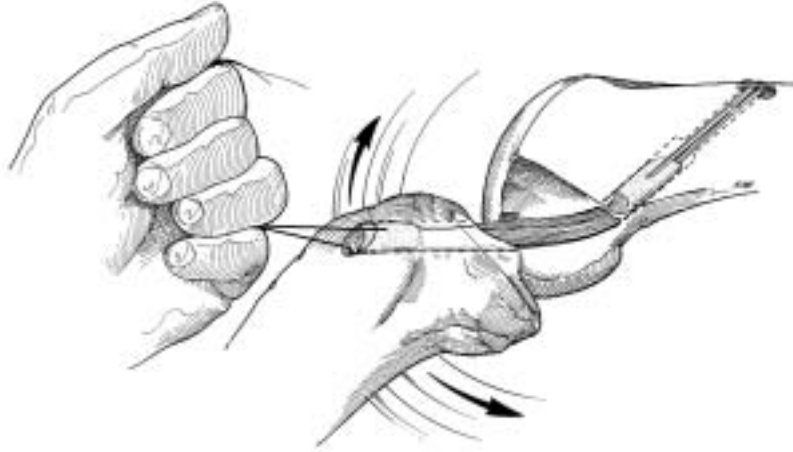

Figure 18: Flex and extend the knee while pulling on the graft prior to tibial graft fixation

### Tibial Fixation

Tension the graft and fix the tibial bone plug as desired, i.e., with a Smith & Nephew interference screw, tying over a screw and washer, or both (Figure 18).



## Additional Instruction

Prior to performing this technique, consult the Instructions for Use documentation provided with individual components — including indications, contraindications, warnings, cautions, and instructions.

Courtesy of Smith & Nephew, Inc.,  
Endoscopy Division

Caution: U.S. Federal law restricts this device to sale by or on the order of a physician.